

CP 0952 NEEDLE SCALER

UTICA PNEUMATIC 533

FOURTH EDITION

JUNE, 1993

Supersedes THIRD Edition JANUARY, 1980

Instruction and Parts Book for

**PNEUMATIC
NEEDLE SCALER**

CP-952 Model "A"

UTICA PNEUMATIC 533



**Chicago
Pneumatic**

CP-952 NEEDLE SCALER Model "A"

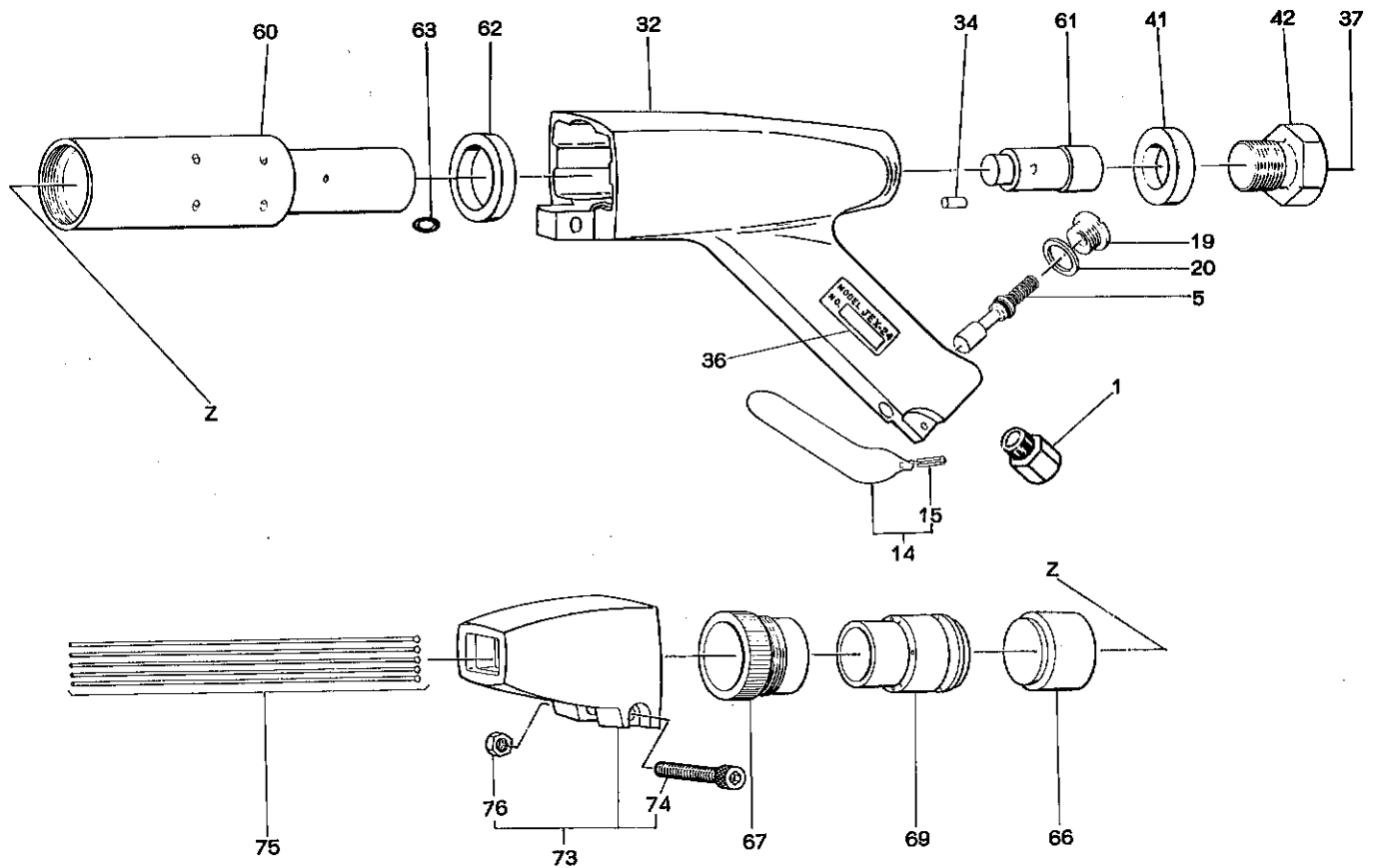

Index No.	CP Part No.	Description	No. Req'd.	Index No.	CP Part No.	Description	No. Req'd.
1	NP-123898	Bushing-Air Inlet	1	62	NP-123909	Washer-Cylinder	1
5	NP-123925	Throttle Valve Ass'y	1	63	NP-123910	"O" Ring	1
14	NP-123916	Lever-Throttle	1	66	NP-123917	Anvil	1
15	NP-123891	Pin-Roll	1	67	NP-123919	Retainer-Needle Holder	1
19	NP-123923	Cap-Valve	1	69	NP-123922	Holder-Needle (3 MM)	1
20	NP-123924	Gasket-Cap	1		NP-123918	Holder-Needle (2 MM)	
32	NP-123908	Housing	1	73	NP-123920	Needle Guide Ass'y	1
34	NP-123912	Pin-Cylinder Lock	1	74	NP-123921	Screw-Socket Head	1
36	NP-124067	Decal-Patent	1		NP-123927	Wrench-Hex.	1
37	NP-124065	Plate-Name (Not Shown)	1	75	NP-123902	Set-Needle (3 MM) (Consists of 23 Steel Needles)	1
41	NP-123914	Washer-Rear Plug	1		NP-123906	Set-Needle (2 MM) (Consists of 53 Steel Needles)	
42	NP-123915	Plug-Housing	1				
60	NP-123911	Cylinder	1				
61	NP-123913	Piston	1	76	KF-124267	Nut M8	1

GENERAL INSTRUCTIONS**Air Supply**

For uniform performance, a regulated supply of clean, dry air at 90 psi air pressure AT THE TOOL is required. The use of 3/8" air hose or larger with fittings of 9/32" minimum ID is recommended. The use of a C-104087 CHICAGO PNEUMATIC Air Line Filter and a C-104092 CHICAGO PNEUMATIC Air Line Pressure Regulator, mounted as closely as possible to the tool, are recommended for efficient operation.

Preparing for Operation

Daily before using and before putting a new or an old Scaler into service, pour about one tablespoonful of recommended oil into the tool air inlet. Blow out air line to clear it of accumulated dirt and moisture, connect tool and operate on partial throttle to allow oil to be carried to interior of tool.

Lubrication

Daily before using and after each four hours of operation, pour about one tablespoonful of recommended oil into tool air inlet and operate as outlined under "Preparing For Operation."

The use of a C-104102 CHICAGO PNEUMATIC Air Line Lubricator mounted at the end of each air pipe leading to this pneumatic tool is recommended to assure a constant and adequate supply of oil to the cylinder.

Recommended Lubricants

CHICAGO PNEUMATIC Airoilene Oil which contains moisture absorbent, rust inhibiting additives and will not separate while the tool is idle, is recommended for use in this pneumatic tool and may be purchased under the following symbols:

1 gal. can -----P-089507
5 gal. can -----P-089508

If recommended oil is not available, use a spindle or turbine grade oil with a viscosity of 100-150 SUS at 100°F which contains a rust inhibitor.

Operating/Safety Cautions

Never operate Needle Scaler without needles in place. Always hold Needles against work before depressing Throttle Lever.

Always wear approved eye protection to avoid personal injury.

When using Needle Scaler hold needles firmly against work but do not press so hard that needles are prevented from hammering surface.

Loss of Power/Erratic Action

Loss of power or erratic action may be caused by factors outside the tool proper. Make the following checks.

1. Check air pressure. For rated performance, 90 psi air pressure is required AT THE TOOL with the tool operating. A drop in air pressure may be caused

by lowered compressor output, excessive drain on the air line or by the use of hose or connections of improper size or poor condition.

2. Check for wet or dirty air. Wet air tends to wash lubricant away from the cylinder and to rust and corrode the tool. Dirt and foreign matter in the air supply will impede action of the piston and cause damage to the tool.

If the above are in order, make the following checks on the tool itself.

1. Check lubrication. Disconnect tool and pour a liberal quantity of recommended oil cut with an equal amount of kerosene into tool air inlet. With needles in the tool and the needles against a firm support, operate tool on partial throttle to flush out gum and foreign matter.

2. Check mechanical parts of tool. Disassemble tool and check for plugged air porting and for worn parts.

Replace worn or broken parts, relubricate and reassemble tool.

Maintenance

Do not penalize the operator by requiring him to use a tool which is not in first class condition. Regular inspection and immediate repair of minor faults will avoid more extensive future repairs and maintain the tool at its highest efficiency.

1. Keep tool properly lubricated.
2. Provide 90 psi of clean, dry air AT THE TOOL.
3. Set up and maintain a repair and replacement program scheduled at regular intervals.

To Replace Needles

1. Remove Allen Screw (74) from Needle Guide Housing (73), remove Needle Guide Housing from Housing (32).
2. Unscrew and remove Needle Holder Retainer (67) from Cylinder (60).
3. Remove Needle Holder (69) with Needles (75).
4. Place new Needles in Needle Holder and reassemble.
5. Make sure flat guide on Housing (32) engages slot in Needle Guide Housing (73).
6. Tighten Allen Screw (74) firmly.

Disassembly

1. Remove Needle Guide Housing (73) and Needle Holder (69) as outlined above.
2. Remove Anvil (66) from Cylinder (60).
3. Using vise blocks, clamp handle portion of Housing (32) firmly in a vise; loosen (do not remove) Housing Plug (42) -(turn counter-clockwise 7 to 10 times).
4. Jar Housing Plug (42) lightly on a block of wood or floor, remove Housing Plug, Piston (61) and Cylinder Lock Pin (34) from Housing.
5. Remove Cylinder (60) from Housing (32), if necessary to replace remove Cylinder Washer (62).

6. Unscrew and remove Valve Cap (19), Cap Gasket (20) and Throttle Valve (5) from Housing.
7. Unscrew and remove Air Inlet Bushing (1), from Housing.
8. Drive Roll Pin (15) out of Housing and remove Throttle Lever (14).

Assembly

1. Place Throttle Lever (14) in Housing (32) and secure in place with Roll Pin (15).
2. Screw Air Inlet Bushing (1) into Housing.

3. Place Throttle Valve (5) in Housing; secure in place with Cap Gasket (20) and Valve Cap (19).
4. Place Cylinder Lock Pin (34) in Housing, place Cylinder Washer (62) on Cylinder (60). Assemble Cylinder in Housing engaging Cylinder Lock Pin.
5. Place Piston (61) in Cylinder, place Rear Plug Washer (41) on Housing Plug (42).
6. Screw Housing Plug tightly into Cylinder.
7. Assemble Anvil (66) in Cylinder (60) making sure flat surface of Anvil will face Needle Holder.
8. Assemble Needle Guide Housing as outlined under "To Replace Needles" on page 3.

TYPICAL AIR HOSE AND COUPLING HOOK-UP

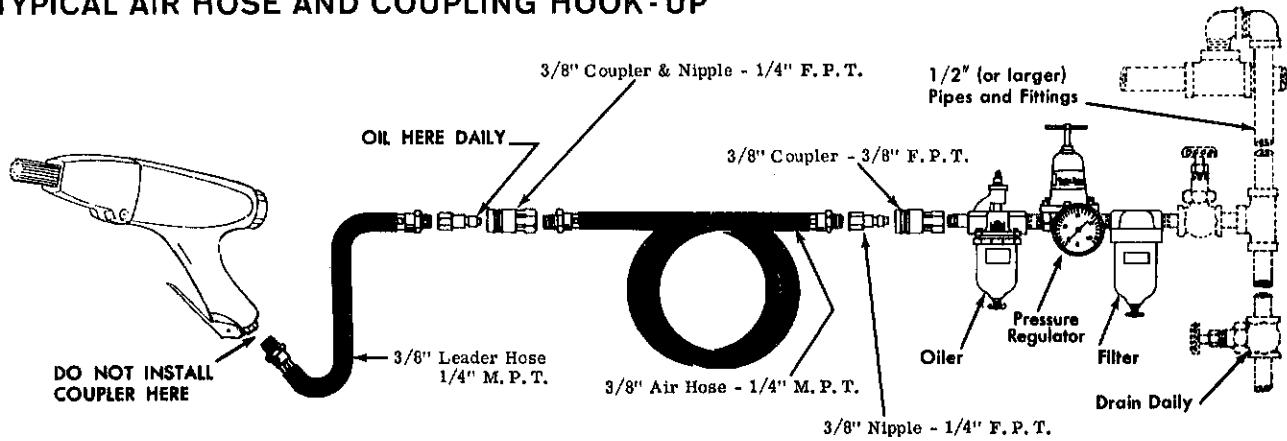

**Chicago
Pneumatic**

2200 Bleecker Street
Utica, New York 13501
Telephone 315-792-2600
FAX 315-792-2651